

# CPSC Handbook for Resale Stores and Product Resellers



CPSC Publication #254

# Introduction

On August 14, 2008, the President signed the Consumer Product Safety Improvement Act of 2008 (CPSIA) into law. This *Handbook for Resale Stores and Product Resellers* was created by the U.S. Consumer Product Safety Commission (CPSC) to help sellers of used products understand the new law and existing regulations.

The implementation of the CPSIA will have dramatic changes for the marketplace. Selling recalled products is now unlawful. The law sets strict limits for lead in paint and for lead content. Additionally, three types of phthalates are permanently prohibited in certain toys and child care articles and three other phthalates are prohibited on an interim basis in certain child care articles and children's product that can be placed in a child's mouth.

The purpose of this Handbook is to help you to identify the types of products that are affected and to understand how to comply with the law, so you can keep unsafe products out of the hands of consumers. Consumers who regularly buy used products may also find this information helpful in avoiding products that could harm them or their family.

New requirements on importers and manufacturers of products should lead to safer products in the resale market in the future, but right now, resellers need to be able to determine what was manufactured in the past that may no longer be compliant. This Handbook will help you make sound business decisions to protect yourself and your customers. Make sure you visit our Web site - [www.cpsc.gov](http://www.cpsc.gov) - frequently for updated information.

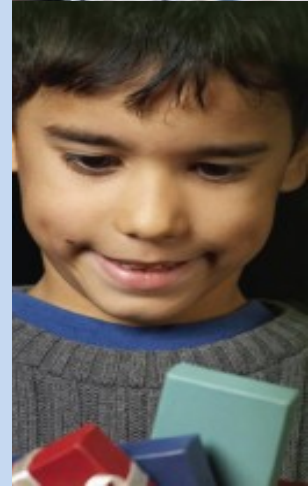

# Table of Contents

<b>The Basics.....</b>	<b>3</b>
<b>What is a Consumer Product?.....</b>	<b>3</b>
<b>What You Cannot Sell.....</b>	<b>3</b>
<b>General Advice to Resellers.....</b>	<b>4</b>
<b>Recalled Products.....</b>	<b>5</b>
<b>Lead in Children’s Products.....</b>	<b>6</b>
<b>Phthalates in Toys and Child Care Articles.....</b>	<b>8</b>
<b>Small Parts.....</b>	<b>10</b>
<b>Clothing.....</b>	<b>11</b>
<b>Cribs.....</b>	<b>12</b>
<b>Mesh-Sided Play Yards and Cribs, Portable Wooden Cribs, Wooden Playpens.....</b>	<b>14</b>
<b>Magnetic Toys.....</b>	<b>16</b>
<b>Combination Infant Car Seats/Carriers.....</b>	<b>17</b>
<b>Baby Walkers.....</b>	<b>18</b>
<b>Toy Chests.....</b>	<b>19</b>
<b>Bath Seats.....</b>	<b>20</b>
<b>Hair Dryers.....</b>	<b>21</b>
<b>Bunk Beds for Children.....</b>	<b>22</b>
<b>Bean Bag Chairs.....</b>	<b>24</b>
<b>Mattresses.....</b>	<b>25</b>
<b>Halogen Floor Lamps.....</b>	<b>26</b>
<b>Additional Resources.....</b>	<b>27</b>

# The Basics

This handbook will help sellers of used products identify types of potentially hazardous products that could harm children or others. CPSC's laws and regulations apply to *anyone* who sells or distributes consumer products. This includes thrift stores, consignment stores, charities, and individuals holding yard sales and flea markets.

## You are not required to test your products for safety.

However, resellers (including those who sell on auction Web sites) cannot knowingly sell products that do not meet the requirements of the law. You can protect yourself by screening for violative products. Ignorance of the law is not an excuse. But more importantly, as a business person, you do not want to sell products that have the potential to cause harm to anyone, especially a child.

## What you cannot sell or offer for sale:

- Products that have been **recalled** by CPSC. (see page 5)
- Toys and other articles intended for use by children, and any furniture, with **paint or other surface coatings containing lead** over specified amounts. (see pages 6-7)
- Products primarily intended for children age 12 or younger with **lead content** over a specific amount. (see pages 6-7)
- Certain toys or child care articles that contain any one of six prohibited chemicals known as **phthalates**, which are primarily used as plasticizers. (see pages 9-10)
- Other products that violate CPSC's safety standards, bans, rules or regulations or otherwise present a substantial product hazard. (see pages 11-29)

## What is a Consumer Product?

A consumer product, for the purposes of this Handbook, is any product that is found in or around the home, a school, or in a recreational setting, including furniture, appliances, rugs, curtains, bed linens, wearing apparel, jewelry, toys, sports equipment and electronics.

Exceptions include tobacco products, motor vehicles and motor vehicle equipment, pesticides, firearms and ammunition, aircraft and aircraft equipment, boats, drugs, medical devices, cosmetics and food – these products are regulated by other federal agencies.

## General Advice to Resellers

Familiarize yourself with the types of products and categories of hazards that have been subject to recalls and may be in your store. As you read the descriptions of the hazards in the recall notices, you will get a better idea of what problems to look for in various products and what to accept/decline through purchase or donation.

There will be more product specific information later in this booklet to target some of the more dangerous products that our investigators have found in resale stores.



- Get CPSC's recall notices and other safety information at [www.cpsc.gov](http://www.cpsc.gov). You can also receive information automatically via e-mail by subscribing on our Web site.

- If you do not have access to e-mail, a partial listing of recent recalls is available in THE SAFETY NEWS, a quarterly publication. To subscribe, write to: CPSC

4330 East West Highway  
Bethesda, MD 20814

- Call CPSC's toll-free hotline at (800) 638-2772 for information on product recalls in English and Spanish.

If you should happen to sell or offer for sale a product in violation of the CPSIA or other law, CPSC's response will vary depending upon the circumstances, including the nature of the product defect, the number of products, the severity of the risk of injury associated with the product and the type of violation. The Commission's response would also take into account the fact that you may be a small business.

CPSC's goal is to help you to avoid future violations and protect your customers, not to put you out of business. If you learn that one of the products you sell violates the law or presents a hazard, immediately inform the Commission. You can [report a potentially defective or hazardous product](#) on CPSC's Web site ([www.cpsc.gov](http://www.cpsc.gov)) or by phone at (800) 638-2772.

# Recalled Products

Each year, CPSC recalls several hundred types of consumer products. These include toys, nursery furniture, home appliances, clothing, power tools, sports equipment and many other products that people use in and around their homes and recreational settings. These recalled products pose a wide variety of hazards to children and adults. For a number of years, the CPSC has been encouraging resale stores not to accept, buy, or sell recalled products. CPSC studied resale and thrift stores nationwide in 1999 and found that 69 percent were selling products that had been recalled, banned, or did not meet current safety standards.

Under the new law, it is now illegal to sell ANY recalled product (for adults as well as children). If you are in the business of reselling products, you are expected to know the laws, rules and regulations that apply to your business, including whether or not a product you are selling has been recalled for a safety issue. Before taking a product into inventory or selling it, check the CPSC Web site for dangerous recalled products, including cribs, play yards, strollers, high chairs, toys with magnets, toys that are choking hazards, and other products. You can search by product type, company name, product description, hazard, country of manufacture and by the month and year in which the recall took place.



**It is against the law to sell a recalled product; check the CPSC Web site or [www.recalls.gov](http://www.recalls.gov) before selling.**

**A special note on nursery furniture and other infant items:** Products used in the nursery, especially cribs and bassinets, have caused deaths and have been the subject of numerous recalls of millions of units. For this reason you should check our Web site recall list, and read the section later in this booklet for more specific things to look for on cribs, play pens and play yards. Do not sell any broken or rickety nursery furniture even if it has not been recalled. A baby's life could depend upon it.

# Lead in Children's Products

Children's products (ones designed or intended primarily for children 12 years of age or younger) cannot be sold if they have more than the allowable limit of lead content. Toys, clothes, furniture, books, jewelry, blankets, games, CDs/DVDs, strollers, and footwear may all be considered children's products. As far as determining what is a children's product, you can evaluate items based on two factors:

- Is the product commonly recognized by consumers as being intended for use by a child 12 years of age or younger?
- Is there any packaging, labeling, advertising or other material that might indicate the manufacturer's intention as to the appropriate age grading of the product?

Products designed or intended primarily for older children or adults are not subject to the lead limits. There is a separate lower limit on the amount of lead that can be in the paint or surface coatings of toys, other articles intended for use by children for any age and on any furniture. A ban on excessive lead in paint and surface coatings has been in effect for over 30 years. The CPSIA lowers the amount of lead that is permitted.

## How can I determine if something has lead?

Resellers, in particular, need to make sound business decisions about the products they sell. As a practical matter, you can:

- Test the product (though not required);
- Not accept the product;
- Use your best judgment based on your knowledge of the product; or,
- Contact the manufacturer about questionable products.

It would make sense to test, rather than discard, any suspect children's products that have a high resale value. You may want to hire a qualified, trained person in your area who can quickly screen all of your suspect products with a handheld device called an X-Ray Fluorescence (XRF) machine. You should not rely on commercially sold lead testing kits that are unreliable and can give both "false positive" or "false negative" results.

## Exclusions to the Lead Limits

CPSC is currently working to determine exclusions to the lead content limits. Until the Commission issues final rules in these areas, certain products and materials (see table on the following page) can be sold as children's products without risk of penalties by the Commission provided the seller does not have actual knowledge that the products have more than the acceptable lead limit. Sellers will not be immune from prosecution if CPSC's Office of Compliance finds that someone had actual knowledge that one of these children's products contained lead or continued to distribute or sell such a product after being put on notice by CPSC. Agency staff will seek recalls of violative children's products or other corrective actions, where appropriate.

## Commonly Resold Children's Products

Items made entirely of wood (without paint, surface coatings or hardware)	OK to sell
Clothes, Blankets and other items made entirely of <ul style="list-style-type: none"> <li>• Dyed or undyed textiles (cotton, wool, hemp, nylon, etc.)</li> <li>• Dyed or undyed yarn</li> <li>• Non-metallic thread, trim, hook-and-loop (Velcro) and elastic</li> </ul>	OK to sell
Clothes with rhinestones, metal or vinyl/plastic snaps, zippers, grommets, closures or appliqués.	Best to test, contact the manufacturer, or not sell
Inexpensive children's metal jewelry	Best to test, contact the manufacturer, or not sell
Jewelry and other items made entirely of: <ul style="list-style-type: none"> <li>• Surgical steel,</li> <li>• Precious metals such as gold (at least 10 karat), sterling silver (at least 925/1000),</li> <li>• Precious and semiprecious gemstones (excluding a list of stones that are associated in nature with lead), or</li> <li>• Natural or cultured pearls</li> </ul>	OK to sell
Children's books printed after 1985 that are conventionally printed and intended to be read (as opposed to used for play)	OK to sell; however, books with metal spiral bindings have been recalled for lead paint.
Vintage children's books and other collectibles not considered primarily intended for children	OK to sell
Certain educational materials, such as chemistry sets	OK to sell



# Phthalates in Toys and Child Care Articles



## What are phthalates?

Phthalates are a group of chemicals that are used, among other things, to make vinyl and other plastics soft and flexible. Many types of phthalates are in use today. As of February 10, 2009, three have been permanently prohibited in the United States for use in certain products and three more are prohibited pending further action by CPSC.

## What products are covered by the prohibition on the use of phthalates?

The scope of the phthalates restrictions is narrower than the lead standard, which covers all children's products. Three phthalates, DEHP, DBP, and BBP, have been permanently banned in concentrations of more than 0.1% in "children's toys" or "child care articles."

- A "children's toy" is a product intended for a child 12 years of age or younger for use when playing. General use balls, bath toys/bath books, dolls and inflatable pool toys are examples of toys that are covered by the law and might contain phthalates. Bikes, musical instruments, and sporting goods (except for their toy counterparts) are not considered toys and are therefore not affected by the ban.
- A "child care article" is a product that a child 3 and younger would use for sleeping, feeding, sucking or teething. Bibs, child placemats, cribs, booster seats, pacifiers and teethingers are child care articles that are covered by the law and might contain phthalates.

Three additional phthalates, DINP, DIDP, and DnOP, have been prohibited in concentrations of more than 0.1% pending further study and review by the Commission and a group of outside experts. This interim prohibition applies to: (a) child care articles, and (b) toys that can be placed in a child's mouth or brought to the mouth and kept in the mouth so that they can be sucked or chewed (for example: squeeze toys, teethingers, bathtub toys and uninflated pool toys).

## **How can I tell if a product contains a prohibited phthalate?**

As with lead, you are not required to test your products for phthalates or to certify that they do not contain prohibited phthalates. There is, however, no easy way to tell whether a product contains a phthalate or what kind of phthalate it contains. Unlike lead, where there is a reliable screening tool (the X-ray Fluorescence machine), there is not a screening device to detect the presence of phthalates.

**With phthalates, your safest course is not to sell or accept certain products (unless you know they don't contain phthalates).**

### **CPSC will focus its enforcement efforts on:**

- Bath toys, “play” books and other plastic toys (especially those made of polyvinyl chloride) that are intended for young children and can be put in the mouth.
- Soft plastic infant and baby products that can be easily grasped.

## Small Parts

Children under 3 can choke on, inhale, or swallow small objects they may “mouth.” Toys and other articles that are intended for use by children under 3 and that are or have small parts, or that produce small parts when broken, are banned and should not be sold.

Resellers should screen products for children under 3 that could present a choking hazard. Toys, books or games that would appeal to a younger child and have small parts or are easily breakable into small parts should not be sold. This would include dolls and stuffed toys that have eyes, noses or other small parts that are not fastened securely, puzzles, nursery equipment, infant furniture and equipment such as playpens, strollers, and baby bouncers and exercisers.

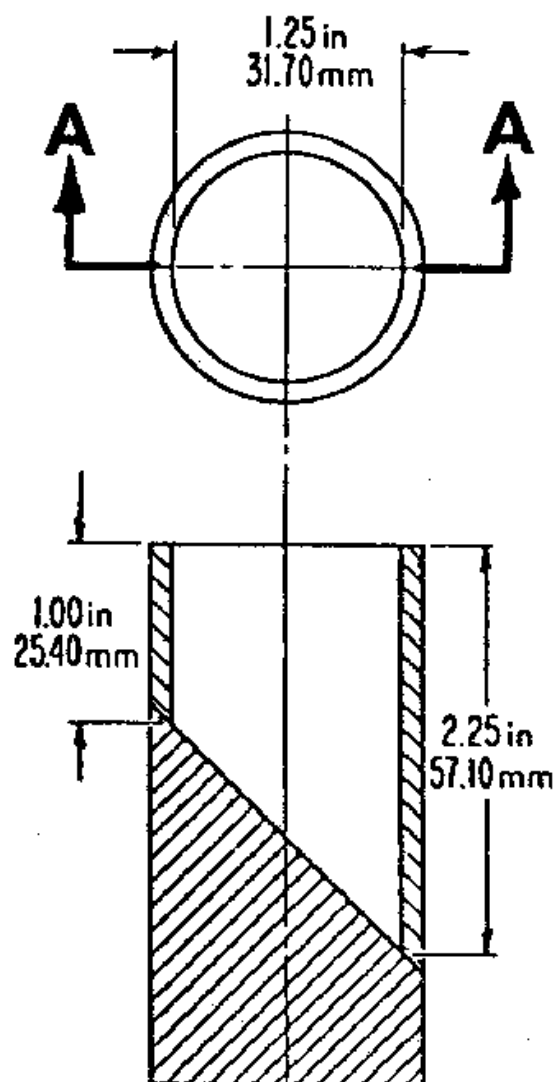

Small Parts Cylinder

A small part can be any object (whole or piece of a toy or article) that fits completely into a specially designed test cylinder 2.25 inches long by 1.25 inches wide that approximates the size of the fully expanded throat of a child under 3 years old (see figure).

# Clothing

**All clothing** is subject to the general wearing apparel standard, which sets a flammability standard for clothing textiles. Most commercially-made clothing in your possession likely meets the general flammability standard. **Children's clothing** is more complicated. There are generally four areas to scrutinize:

**1) Flammability:** While children's daywear must meet the general wearing apparel standard, children's sleepwear (sized for children older than 9 months through size 14) is subject to more stringent flammability requirements. Sleepwear garments made from cotton or a cotton blend must either be treated with a flame retardant or bear a label indicating that they are not flame resistant and must therefore be snug fitting when worn. These garments will look small to you because they are meant to hug a child's body. Children's robes and lounge wear must also meet the sleepwear flammability requirements. Sleepwear made from polyester complies with the sleepwear standard. **If you have any children's robes, loose fitting pajamas, nightgowns or lounge wear made from cotton or a cotton blend, they may not meet the applicable flammability standard.**

**2) Lead:** Untreated natural fibers (like cotton and wool) and non-metallic fasteners and trim such as Velcro, elastic, etc. do not contain lead. **Lead can be present in zippers, snaps and any other metal and plastic adornments on a child's clothing.**

**3) Small Parts:** There have been numerous recalls of clothing intended for children under the age of 3. If any snaps, pom-poms, zipper pulls or buttons can be pulled off of a small child's garment, it should not be sold. So give a strong tug to these pieces before you sell them. **If something comes off that could choke a child under the age of 3, do not sell the garment.**

**4) Drawstrings:** CPSC has recalled numerous children's garments that have long drawstrings at the neck or waist. Children have strangled to death when drawstrings were caught on playground equipment or a crib. They have also caught bus doors and caused children to be dragged and killed or seriously injured. From 1985 through July 2008, there were at least 27 reported deaths and 70 non-fatal incidents to children aged 15 years and younger related to drawstrings.

**Before selling children's (age 15 years and younger) check garments with drawstrings: for hood/neck drawstrings, remove drawstrings from the hood and neck of jackets and sweatshirts; for waist/bottom drawstrings, trim drawstrings so that no more than to 3 inches extends from the garment on either side.**



# Cribs

**THE PRODUCT:** Cribs that don't meet current safety standards.

**THE HAZARDS:** Suffocation, strangulation. More infants die each year in incidents involving cribs than from any other nursery product.

Previously used cribs can host a variety of hidden hazards that most consumers may not detect. Thus, unless the crib can be fully assembled and operates correctly, contains all the original hardware and the instructions are included, the crib should not be sold. If you choose to sell a used crib, follow the checklist on the following page.

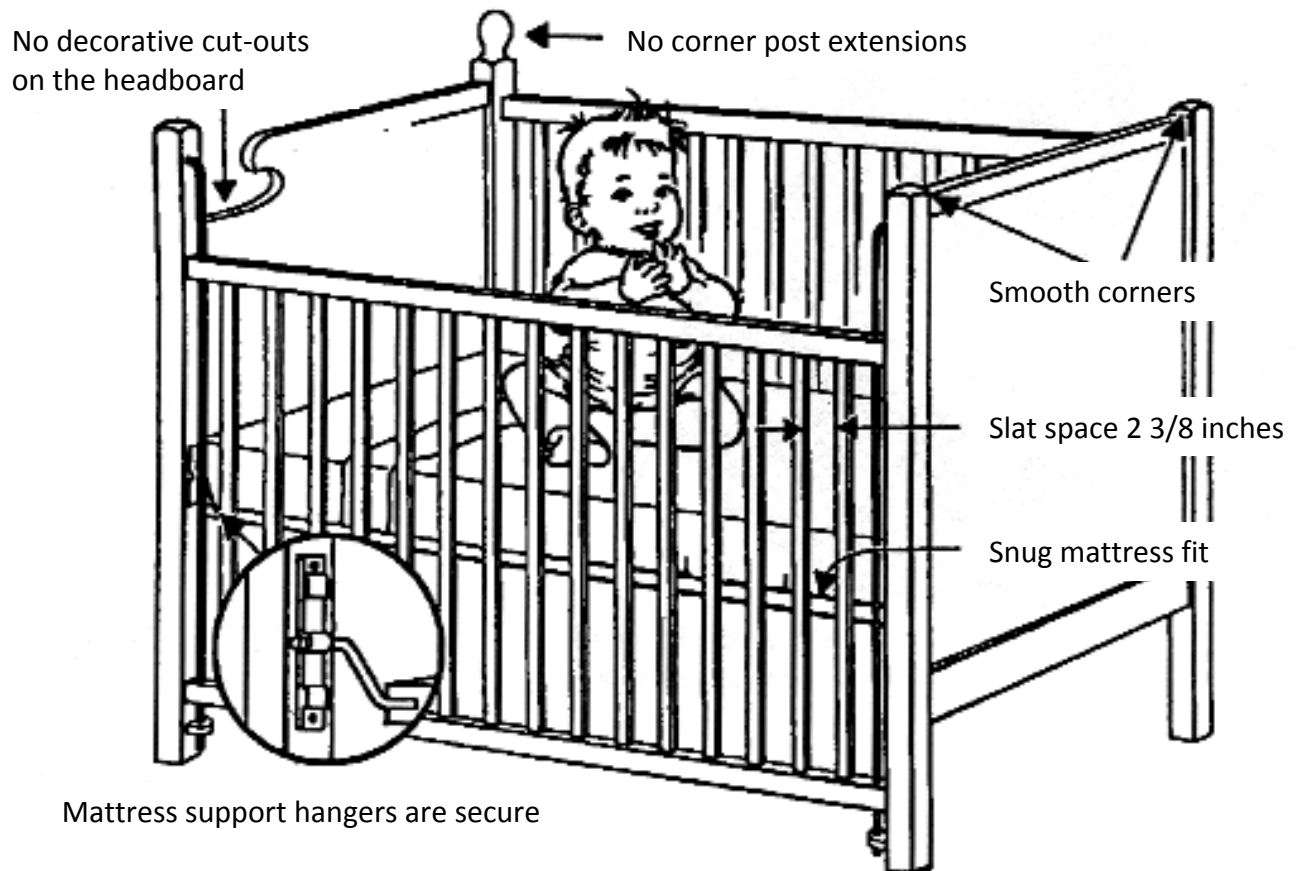

## WHAT TO DO:

- **Inspect** each crib to be sure it has the following safety features:
  - make sure your product is not the subject of a recall;
  - slats spaced no more than 2 3/8 inches apart;
  - no missing or loose slats;
  - no recalled crib with drop side (millions of cribs with drop sides have been recalled)
  - a properly-sized mattress. The mattress is too small if you can fit more than two fingers between the edge of the mattress and the side of the crib. An infant can get his head or body wedged in the extra space and suffocate.
  - corner posts are no more than 1/16 inch high. They can be catch points for objects or clothing worn by a child and cause strangulation.
  - no missing, broken or loose hardware;
  - no decorative cutouts in the headboard or footboard. Cutouts can entrap a child's head; and
  - no unsecured mattress support hangers that can be easily dislodged. Children can be entrapped and suffocate.
- CPSC has conducted numerous recalls of cribs over the past 15 years, which can be found at [www.cpsc.gov](http://www.cpsc.gov).
- **Don't sell** cribs that have any of the hazards described in the list above. **Destroy them.**

# Mesh-Sided Play Yards and Cribs, Portable Wooden Cribs, Wooden Playpens

**THE PRODUCTS:** Mesh-sided play yards (playpens) and cribs, wooden play yards, and portable wooden cribs that don't meet current safety standards.

**THE HAZARDS:** Suffocation, strangulation, choking.

The side of a mesh play yard or portable crib left in the down position forms a pocket that an infant can roll into and become trapped, causing suffocation. The top rails of a play yard or portable crib with a rotating center hinge may collapse and form an acute V-shape that can entrap a child's neck and cause the child to strangle.

A toddler can strangle in a play yard or portable crib with protruding rivets if a pacifier string or loose (or loosely woven) clothing catches on one. An infant or toddler can also strangle if his head gets caught in tears in the mesh. A teething infant can chew off pieces of the vinyl covering of a play yard's railing and choke.

A baby's body, except for the head, can pass entirely between the slats of a wooden play yard or portable wooden crib if the slats are more than 2 3/8 inches apart, and the baby may strangle.

Warning labels

Areas of possible child entrapment

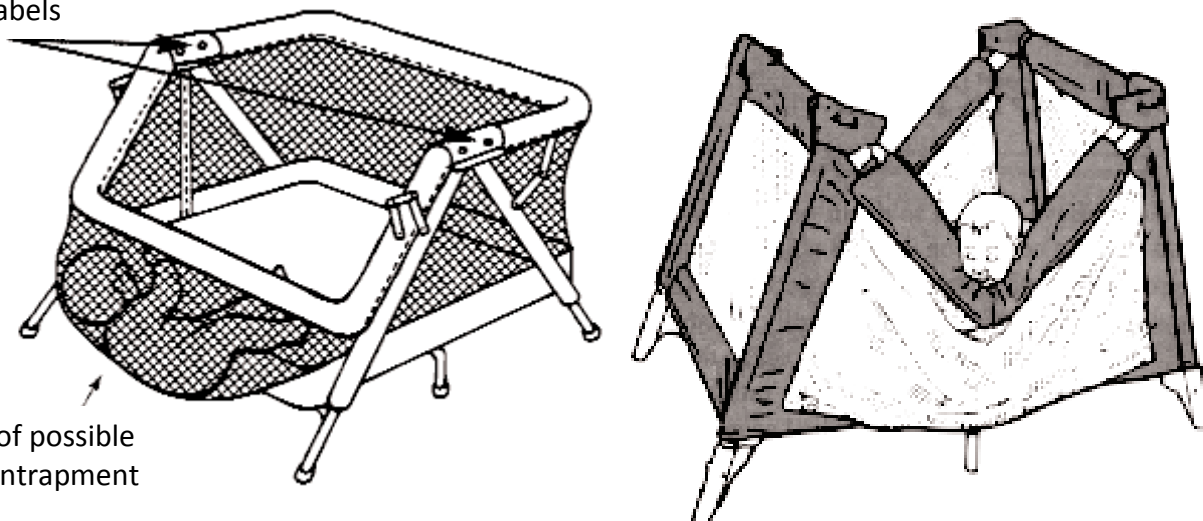

## WHAT TO DO:

- **Inspect** all mesh-sided play yards and portable cribs, and play yards with wooden side slats and portable wooden cribs for the following safety features:
  - mesh-sided play yards and portable cribs with drop sides have warning labels that say the sides should never be left in the down position;
  - top rails of mesh-sided play yards and cribs with a hinge in the center automatically lock when the rails are lifted into the normal use position;
  - mesh-sided play yards or portable cribs have no rivets protruding 1/16 inch or more on the outside of the top rails;
  - the mesh has a small weave (the openings are less than 1/4 inch);
  - the mesh has no tears or loose threads;
  - the mesh is securely attached to the top rail and floor plate;
  - the covering of the top rails has no tears or holes;
  - any staples, rivets, or screws used in construction are not loose or missing; and
  - wooden play yards and portable wooden cribs have slats that are no more than 2 3/8 inches apart and no broken or missing parts.
  
- CPSC has conducted numerous recalls of play yards over the past 15 years, which can be found at [www.cpsc.gov](http://www.cpsc.gov).
  
- **Don't sell** play yards and portable cribs that fail to meet the safety criteria above. **Destroy them.**

# Magnetic Toys

**THE PRODUCT:** Toys containing magnets or magnetic components, such as construction sets, action figures, dolls, and puzzles.

**THE HAZARDS:** Small powerful magnets, like those found in magnetic building sets and other toys, can kill children if ingested/swallowed.

If two or more magnets or magnetic components or a magnet and another metal object (such as a small metal ball) are swallowed separately, they can attract to one another through intestinal walls. This traps the magnets in place and can cause holes (perforations), twisting and/or blockage of the intestines, infection, blood poisoning (sepsis), and death. When multiple magnets are ingested, surgery is required to remove the magnets and sometimes sections of the intestines need to be removed. Small powerful magnets found in other non-toy products, such as jewelry and novelty stones, may present the same hazard.



CPSC is aware of dozens of cases of children being injured from ingesting magnets. A 20 month-old child died and many more children from 10 months to 11 years old required surgery to remove ingested magnets. In many cases, magnets fell out of larger components of toys. Some children swallowed intact toy components containing magnets.

## WHAT TO DO:

- **Don't sell** magnetic toys that have been recalled.
- **Don't sell** any toy that has loose or missing magnetic components.
- Hobby, craft and science kits intended for children over 8 years old may have small magnets, and can be sold provided they are labeled with a warning about the hazard.

# Combination Infant Car Seats/Carriers

**THE PRODUCT:** Certain models of combination infant car seats/carriers that also can be used as infant carriers outside a vehicle that don't meet current safety standards.

**THE HAZARDS:** Skull fracture, concussion, cuts, scrapes, bruises.

When used as an infant carrier, the handles or locks can break, release and/or rotate unexpectedly allowing an infant to fall to the ground or be ejected.

## WHAT TO DO:

- CPSC has conducted numerous recalls of infant car seats/carriers, which can be found at [www.cpsc.gov](http://www.cpsc.gov). Other car seats and automobile booster seats fall under jurisdiction of the National Highway Traffic Safety Administration (NHTSA). For additional information and for a list of these product that have been recalled, visit [www.nhtsa.gov](http://www.nhtsa.gov).
- **Contact the manufacturer** if you have a recalled infant car seat/carrier. It may be able to be repaired to make it safe.
- **Don't sell** a recalled infant car seat/carrier. If you find out the carrier has been recalled and you cannot fix it, **destroy it**.



# Baby Walkers

**THE PRODUCT:** Baby walkers that don't meet current safety standards and fit through standard doorways and don't stop at the top of stairs. (See illustration below.)

The safer style of baby walkers meets a new safety standard and is designed to help prevent injuries and deaths from falls down stairs. (See illustration below.) Rubber-like strips underneath or around the base grip the floor and stop the walker at the edge of a step.

**THE HAZARDS:** Death, skull fracture, concussion, internal injuries, broken bones, cuts, bruises.

In the past, more children were injured with baby walkers than with any other nursery product. Since 1973, walkers have been involved in at least 39 deaths. In 2006, an estimated 3,200 walker-related injuries among children under 15 months old were treated in hospital emergency rooms. Most of these injuries resulted from falls down stairs.

## WHAT TO DO:

- **Inspect** each walker. Each should either be at least 36 inches wide at the base or have gripping strips to help stop it at the edge of a step;
- **Don't sell** baby walkers unless they are one of the safer models, **destroy them.**

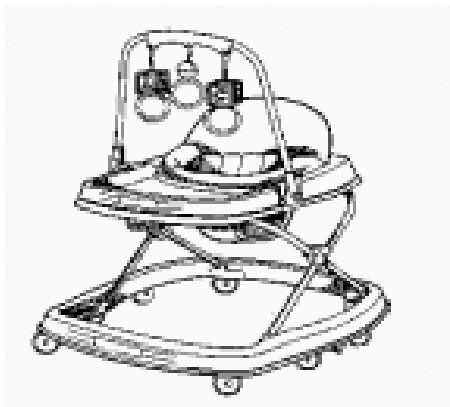

Out-of-date baby walker

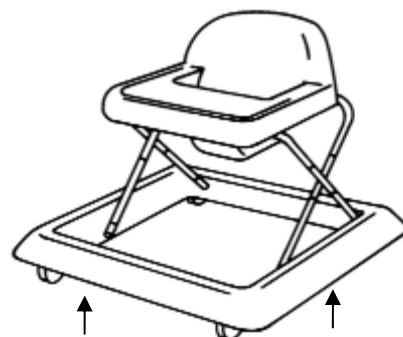

Newer style has a gripping mechanism under the edge to stop the walker at the edge of a step

# Toy Chests

**THE PRODUCT:** Chests and boxes with hinged lids made or used to store toys. This includes those specifically manufactured for toy storage, as well as trunks, cedar chests, wicker chests, footlockers, decorator cubes, wooden storage chests, and other similar items.

**THE HAZARDS:** Strangulation, suffocation, brain damage, crushed and pinched fingers.

Lids can fall on children's heads or necks, causing brain damage or death. Children who climb inside hinged chests or boxes to hide or sleep can suffocate due to lack of air. There have been numerous reports of deaths of children trapped inside chests.

## WHAT TO DO:

- **Inspect** every toy chest and other toy storage unit with a hinged lid to be sure it meets all of the following safety criteria:
  - It has a spring-loaded lid support that will keep the lid open in any position without adjustment (see illustration below);
  - it has no latch or lock that could trap a child inside the chest; and
  - it has two or more ventilation holes or openings near the top of the front or sides.
- **Don't sell** toy chests or other large hinged boxes or chests that could be used for toy storage if they fail to meet the safety criteria above. **Destroy them.**

TOY CHEST  
(meets the standard)

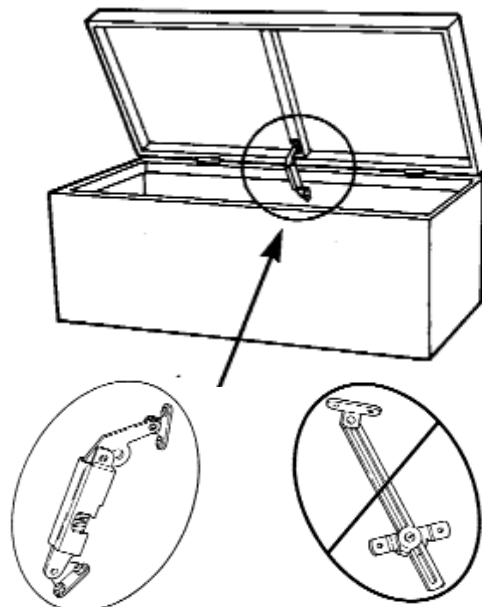

SAFE: Spring-loaded  
lid support

NOT SAFE: Adjustable-friction  
lid support

# Bath Seats

**THE PRODUCT:** Infant Bath Seats or Bath Rings that don't meet current safety standards.

These bathing products are designed as an aid to help caregivers bathe an infant. They are intended for infants who can sit upright, unassisted, not for children who are walking or who can pull themselves up to a standing position.

**THE HAZARDS:** Drowning.

**WHAT TO DO:**

**Don't sell** bath seats that:

- attach to the tub floor with suction cups
- were made before 2007 (see date code stamp on the bottom of the product)
- are broken or damaged
- do not have warnings visible on the product

**Destroy them.**



BATH SEAT  
(meets the standard)

# Hair Dryers

**THE PRODUCT:** Hair dryers that don't have immersion protection devices (see illustration below).

**THE HAZARD:** Electrocution.

Electric voltage is still present when the dryer is plugged in, even if the switch is in the "off" position. A hair dryer without an immersion protection device that is accidentally dropped into water (such as in a sink or bathtub) can electrocute anyone in or touching the water.

Most new hand-held hair dryers have immersion protective devices. Many used ones do not.

There was an average of 16 electrocutions a year involving hand-held hair dryers in the early 1980s, before immersion protection devices were included in their design. Since 2000, three deaths associated with hair dryers have been reported.

## WHAT TO DO:

- **Inspect** all hand-held hair dryers. Look for the following on each:
  - an immersion protection device, which is a large, rectangular-shaped plug at the end of the cord (see the illustration); and
  - the certification mark of a recognized testing laboratory on the hair dryer itself.
- **Don't sell** any hand-held hair dryer that doesn't have an immersion protection device and certification mark from a recognized testing laboratory. **Destroy it.**

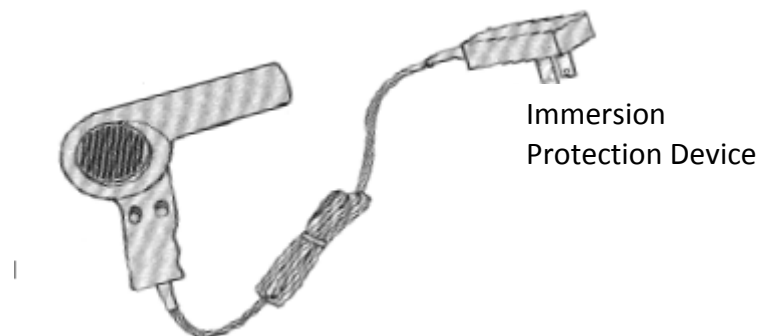

HAND-HELD HAIR DRYER  
(meets the standard)

# Bunk Beds for Children

**THE PRODUCT:** Bunk beds with mattress foundations 30 inches or more above the floor that don't meet current safety standards.

**THE HAZARDS:** Strangulation, suffocation, hanging.

Since 1990, over 70 young children have been reported to have died by strangulation or suffocation from entrapment in bunk beds. Most were 3 years old or younger. Some children strangled when their bodies, but not their heads, slid between a side guardrail and the side bed frame of the upper bunk, leaving their bodies hanging. Some children suffocated when they became trapped in openings within the footboard or headboard, or between the bed and the wall. A few children died when the bed collapsed on top of them.

In addition, from January 1990 through August 2007, CPSC staff is aware of 67 incidents of hanging fatalities involving bunk beds and another product. Some children were hanged upon descent from a top bunk when an article they were wearing became entangled on a vertical protrusion.

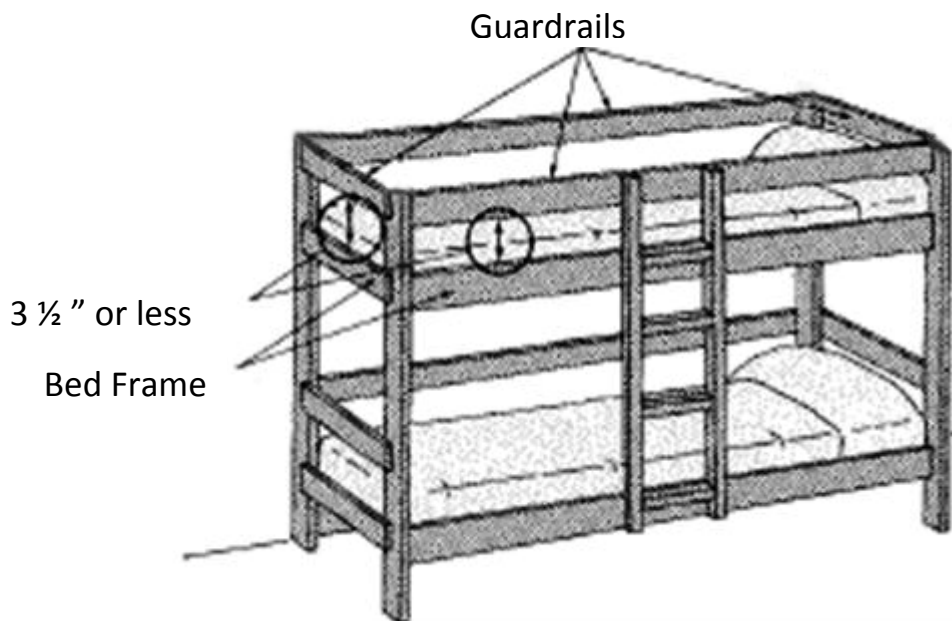

BUNK BED  
(meets the standard)

## WHAT TO DO:

**Inspect** each bunk bed and look for the following safety features:

### TOP BUNK

- a continuous guardrail from end to end on the wall side of the top bunk
- a guardrail no more than 15 inches from either the footboard or headboard on the side away from the wall
- guardrail openings should be less than 3 ½ inches between the guardrail sections and the bed frame
- openings or slats in the headboard and footboard should be less than 3 ½ inches
- the top of the mattress (if there is one) is at least 5 inches below the upper edge of the guardrails
- vertical protrusions along the top surface of the upper bunk are restricted to 3/16 inches or less. This includes ladder stiles, corner posts, and guard rails.

### LOWER BUNK

- either less than 3 ½ inches or more than 9 inches between openings and slats in the headboard and footboard

### UPPER AND LOWER BUNKS

- the mattress (if there is one) is the size specified in the warning label on the bed and/or the mattress fits the frame snugly
- mattress supports are securely fastened to the bed by screws or bolts
- tubular metal bunk beds: no breaks or cracks in the paint or metal around the welds that hold the side rail to the bed frame at all four corners of the upper and lower bunks.

Look for labels on new bunk beds indicating that they meet federal safety standards. **Don't sell** any bunk beds that do not have these labels or meet these safety features. **Destroy them.**

# Bean Bag Chairs

**THE PRODUCT:** Zippered bean bag chairs stuffed with small foam pellets that don't meet current safety standards.

**THE HAZARD:** Suffocation, choking.

Children have unzipped bean bag chairs, crawled inside, inhaled or ingested the foam pellets, and they suffocated. Some have unzipped the chairs, then pulled out the foam pellets and played with them. The pellets clogged their mouths and noses, and they suffocated. Other children choked on the pellets but survived.

CPSC is aware of five reported deaths and at least 27 non-fatal incidents associated with bean bag chairs. Since 1996, bean bag chairs have been manufactured with zippers that young children can't open.

## WHAT TO DO:

- **Inspect** each zippered bean bag chair for the following:
  - the zipper is not visible and can't be opened by young children
  - no stuffing is coming out
- **Pull** at the chair's seams. They shouldn't come apart. If they do, the foam pellets could escape, posing a hazard to children.
- Don't sell any zippered bean bag chair that doesn't meet these safety criteria.  
**Destroy it.**



ZIPPERED BEAN BAG CHAIR  
(recalled product)

# Mattresses

**THE PRODUCT:** Older mattresses that don't meet CPSC's open flame standard (16 CFR Part 1633)

**THE HAZARD:** Fire.

Mattresses manufactured on or after July 1, 2007 must meet the CPSC flammability standard. The mandatory standard is designed to reduce the severity of mattress fires ignited by open flame sources such as candles, matches and lighters.

CPSC estimates that, once fully effective, the new federal flammability standard will prevent as many as 270 deaths and 1,330 injuries every year.

## WHAT TO DO:

- **Inspect** each mattress (and accompanying box spring) for a "Part 1633" compliance label. Further, thrift stores that "renovate" mattresses must do so such that the renovated mattress meets the standard.
  
- **Don't sell** older mattresses that don't meet the new standard. **Destroy them.**

# Halogen Floor Lamps

**THE PRODUCT:** Freestanding floor lamps about six feet tall that use tubular halogen light bulbs (see illustration at right).

**THE HAZARD:** Fire.

A halogen light bulb can heat up to nearly 1,000 degrees Fahrenheit. Flammable material that contacts the bulb may catch fire.

From 1992–1999, CPSC received reports of at least 270 fires and 18 fire-related deaths involving halogen torchiere floor lamps. Halogen torchiere floor lamps manufactured after February 5, 1997, that meet voluntary safety requirements, are made with a wire or glass guard. The guard fits over the glass bulb shield that covers the light bulb and reduces the potential fire hazard. The guard makes it harder for flammable materials to come in contact with the light bulb and catch fire.

**WHAT TO DO:**

**Inspect** each halogen torchiere floor lamp. Look for the following:

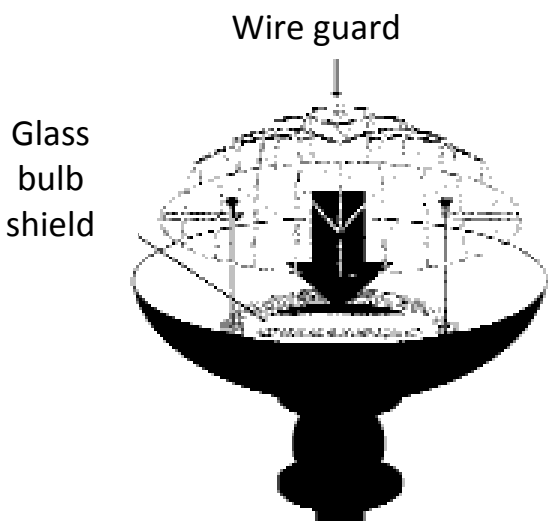

- a wire or glass guard over the glass bulb shield in the bowl at the top of the lamp. The top of the guard should be three inches from the glass bulb shield.
- bulb wattage. The tubular halogen light bulb should not be over 300 watts, even if the original label on the lamp says that a 500-watt bulb can be used.
- the plug. It should be polarized (one blade wider than the other).
- the cord. Inspect the cord for mechanical damage.
- signs of corrosion, bent or loose parts. Any of these may indicate a malfunctioning or potentially hazardous lamp.

**Don't sell** any halogen torchiere floor lamp that doesn't have a wire or glass guard over the glass bulb shield or that has any of the other hazards above. **Destroy it.**

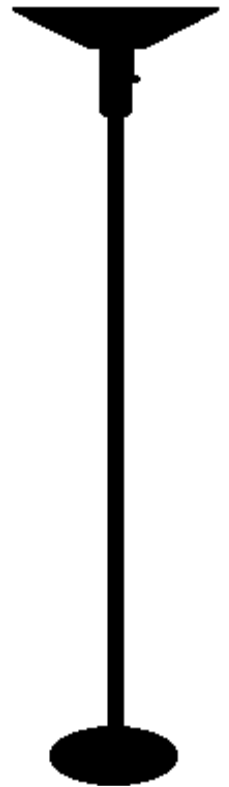

# Additional Resources

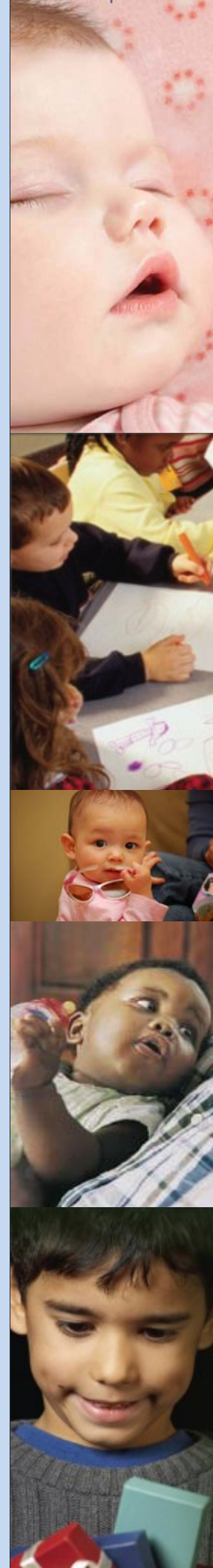

CPSC's Home Page	<a href="http://www.cpsc.gov">www.cpsc.gov</a>
Recalls (all agencies)	<a href="http://www.recalls.gov">www.recalls.gov</a>
Recalls (CPSC only)	<a href="http://www.cpsc.gov/cpscpub/prerel/prerel.html">www.cpsc.gov/cpscpub/prerel/prerel.html</a>
Small Business Information	<a href="http://www.cpsc.gov/businfo/smbus.html">www.cpsc.gov/businfo/smbus.html</a>
Guidance on the CPSIA for Small Business	<a href="http://www.cpsc.gov/about/cpsia/smbus/cpsiasbguide.html">www.cpsc.gov/about/cpsia/smbus/cpsiasbguide.html</a>
Regulations, Laws and Information by Product	<a href="http://www.cpsc.gov/businfo/regsbyproduct.html">www.cpsc.gov/businfo/regsbyproduct.html</a>
Report an Unsafe Product	<a href="http://www.cpsc.gov/talk.html">www.cpsc.gov/talk.html</a>